

Charmate
Great taste. *Good times!*

Lawson 470 Charcoal Smoker & Grill

Model No. CBQ2007



**CHECK
OUT**

www.Charmate.co.nz

**FOR TIPS & TRICKS,
RECIPES, INFO &
DEALS!**

**SHARE
WITH US**

 @CHARMATENATION

 CHARMATENZ

 CHARMATE

- Traditional style smoker for delicious slow cooking and smoking of foods
- Also suitable to use as a charcoal grill
- Durable steel construction
- Two large chrome plated cooking racks
- Lid mounted thermostat for internal heat indication
- Water bowl included to add moisture when cooking
- Size: 470mm (18") diameter x 1120mm high



FOR OUTDOOR USE ONLY

DO NOT OPERATE THIS APPLIANCE BEFORE READING THE INSTRUCTION BOOKLET

DO NOT PLACE ARTICLES ON OR AGAINST THIS APPLIANCE

DO NOT STORE CHEMICALS OR FLAMMABLE MATERIALS OR SPRAY AEROSOLS NEAR THIS APPLIANCE

DO NOT OPERATE THE APPLIANCE INDOORS

DO NOT OPERATE IN AN ENCLOSED AREA. ACCESSIBLE PARTS MAY BE VERY HOT. KEEP YOUNG CHILDREN AWAY.

MINIMUM CLEARANCES FROM COMBUSTIBLE MATERIALS: 3 METRES

Charmate

is a registered trademark of: Sitro Group Australia Pty Ltd - www.sitro.com.au & Aber Living, Hamilton, N.Z - www.charmate.co.nz

Important: Retain these instructions for future use.

Important Safety Warnings

We want you to assemble and use your Charmate Smoker & Grill as safely as possible.



When you see this safety alert symbol please pay particular attention to the information which follows it.

Read all safety warnings and instructions carefully before assembling and operating the Smoker & Grill.



Warning

- Only use this Smoker & Grill on a hard, level, non-combustible, stable surface. Never use on a wooden surface.
- Always use a drip pan/ash guard under Smoker & Grill to protect surface from heat damage and/or discolouration and to catch ashes, embers and drippings. Place a thin layer of water in drip pan/ash guard to help extinguish falling ashes and embers.
- A clearance of at least 3 meters between the smoker and any combustible material (bushes, trees, wooden decks, wooden fences, buildings, etc.) or construction should be maintained at all times when Smoker & Grill is in use.
- Do not place Smoker & Grill under a roof overhang or other enclosed area.
- For outdoor use only. Do not operate Smoker & Grill indoors or in an enclosed area.
- Water bowl should always be used when smoking. Do not allow liquid in water bowl to completely evaporate. Check water bowl every 2 hours and add water if level is low (a sizzling should may indicate a need for water). Follow instructions in “Adding Water or Wood during Cooking” section of this manual.
- Always keep water in the water bowl even after food is removed from Smoker. Water will evaporate and grease in water bowl can catch on fire.
- Do not move Smoker & Grill when water bowl contains hot liquids and while it is in use.
- Do not leave Smoker & Grill unattended when in use.
- Do not store or use Smoker near flammable liquids, gases or where flammable vapours may be present.
- We do not recommend the use of lighting fluid. If you choose to use charcoal lighting fluid, only use lighting fluid approved for lighting charcoal. Carefully read instructions on the charcoal lighting fluid and charcoal prior to use.
- Do not use flammable liquid to light charcoal. Use can cause an explosion possibly leading to severe bodily injury.
- Never add charcoal lighting fluid to hot or even warm charcoal.
- Do not use self-starting charcoal. Use only high grade plain charcoal or charcoal/wood mixture.
- During grilling, grease from meat may drip into the charcoal and cause a grease fire. If this should happen, replace dome lid to suffocate the flame. Do not use water to extinguish grease fires.
- Use caution since flames can flare-up when fresh air suddenly comes in contact with fire. When opening the dome lid, keep hands, face and body safe from hot steam and flame flare-ups. Remove the dome lid by tilting it toward you to allow heat and steam to escape away from your face.
- Use caution when assembling and operating your Smoker & Grill to avoid scrapes or cuts from sharp edges of metal parts.
- Check support brackets to make sure they are secure and notches are upright before each use.
- Place Smoker & Grill in an area where children and pets cannot come into contact with unit. Close supervision is necessary when Smoker & Grill is in use.

- Use caution when lifting or moving Smoker & Grill to prevent strains and back injuries.
- In windy weather, place Smoker & Grill in an outdoor area that is protected from the wind.
- Do not wear loose clothing or allow hair to hang freely while using Smoker & Grill.
- Use caution when reaching into or under Smoker & Grill. Always wear oven mitts or gloves to protect your hands from burns. Avoid touching hot surfaces.
- We advise that a fire extinguisher be on hand. Refer to your local authority to determine proper size and type of fire extinguisher.
- Any accessory attachments not included with this unit are not recommended and may lead to personal injury or property damage.
- Never leave coals and ashes in Smoker & Grill unattended.
- Before Smoker & Grill can be left unattended, remaining coals and ashes must be removed from Smoker & Grill. Use caution to protect yourself and property. Place remaining coals and ashes in a non-combustible metal container and completely saturate with water. Allow coals and water to remain in metal container 24 hours prior to disposing.
- Extinguished coals and ashes should be placed a safe distance from all structures and combustible materials.
- With a garden hose, completely wet the surface beneath and around Smoker to extinguish any ashes, coals or embers which may have fallen during the cooking or cleaning process.
- Store the Smoker & Grill out of reach of children, indoors in a dry location when not in use.
- Do not attempt to service Smoker & Grill other than normal maintenance as explained in “After-Use Safety and Care & Maintenance” sections of this manual.
- Properly dispose of all packaging material.



WARNING

- Use caution and common sense when using your Smoker & Grill.
- Failure to adhere to the safety warnings and guidelines in this manual could result in bodily injury or property damage.
- Please keep this manual for future reference.

ASSEMBLY INSTRUCTIONS

Exploded View

For Easiest Assembly:

- To avoid losing any small components or hardware, assemble your product on a hard level surface that does not have cracks or openings. You may wish to lay down a blanket or similar, to avoid possible damage to the finish during assembly.
- Clear an area large enough to layout all components and hardware.
- Great care has been taken during production to remove sharp edges but you should handle all components with care to avoid injury.
- Check you have all components before beginning.
- When applicable, tighten all hardware connections by hand first. Once the step is completed go back and fully tighten all hardware.
- Follow all steps in order to properly assemble your product.

Typical assembly: approximately ½ hour.

Tools Needed:



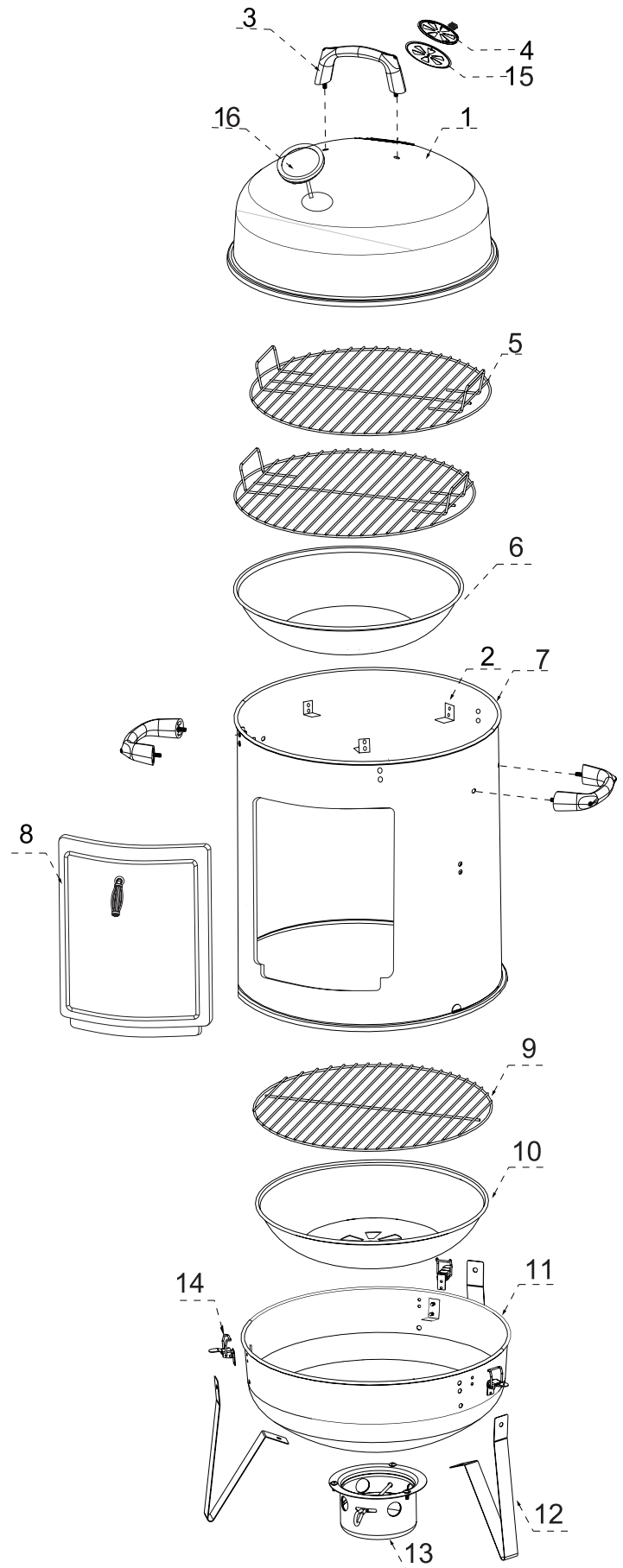





- 5/16" Open End Wrench
- Slotted Screwdriver
- Phillips Head Screwdriver



Parts List

No.	Description	Qty	No.	Description	Qty	No.	Description	Qty
1	Dome Lid	1	7	Upper Body	1	13	Vent/Ash Collector	1
2	Grill Support Brackets	3	8	Door	1	14	Latches	3
3	Handles	3	9	Charcoal Grate	1	15	Ventilation Plate	1
4	Lid Vent	1	10	Charcoal Bowl	1	16	Temperature Gauge	1
5	Top Cooking Grill	1	11	Lower Body	1			
6	Water Bowl	1	12	Legs	3			

Hardware

A. M3x10 Qty. x6		B. Ø6x16 Qty. x12		C. M6x12 Qty. x6		D. M3 Qty. x6	
E. M5 Qty. x7		F. M6 Qty. x6		G. M6 Qty. x6		H. M5x10 Qty. x7	

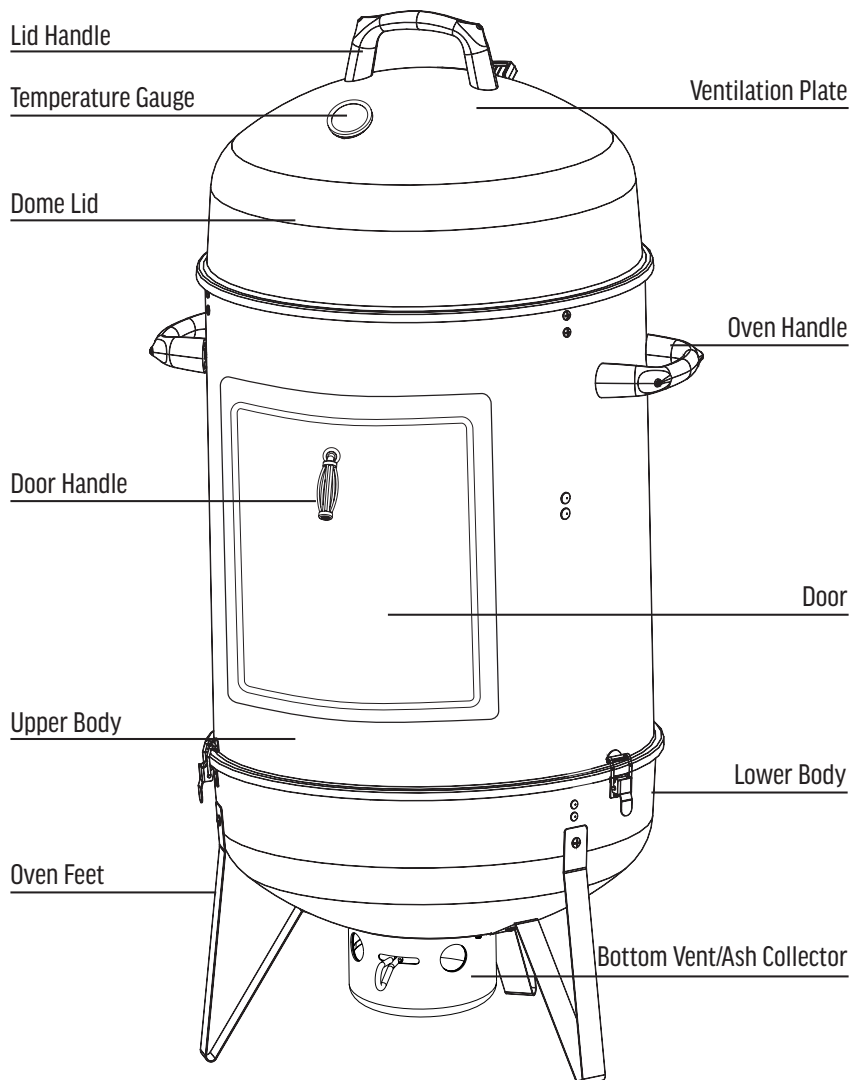

ASSEMBLY INSTRUCTIONS

STEP 1

Attach legs (12) to lower body (11) using 6 x bolts (C), washers (B) and nuts (F).

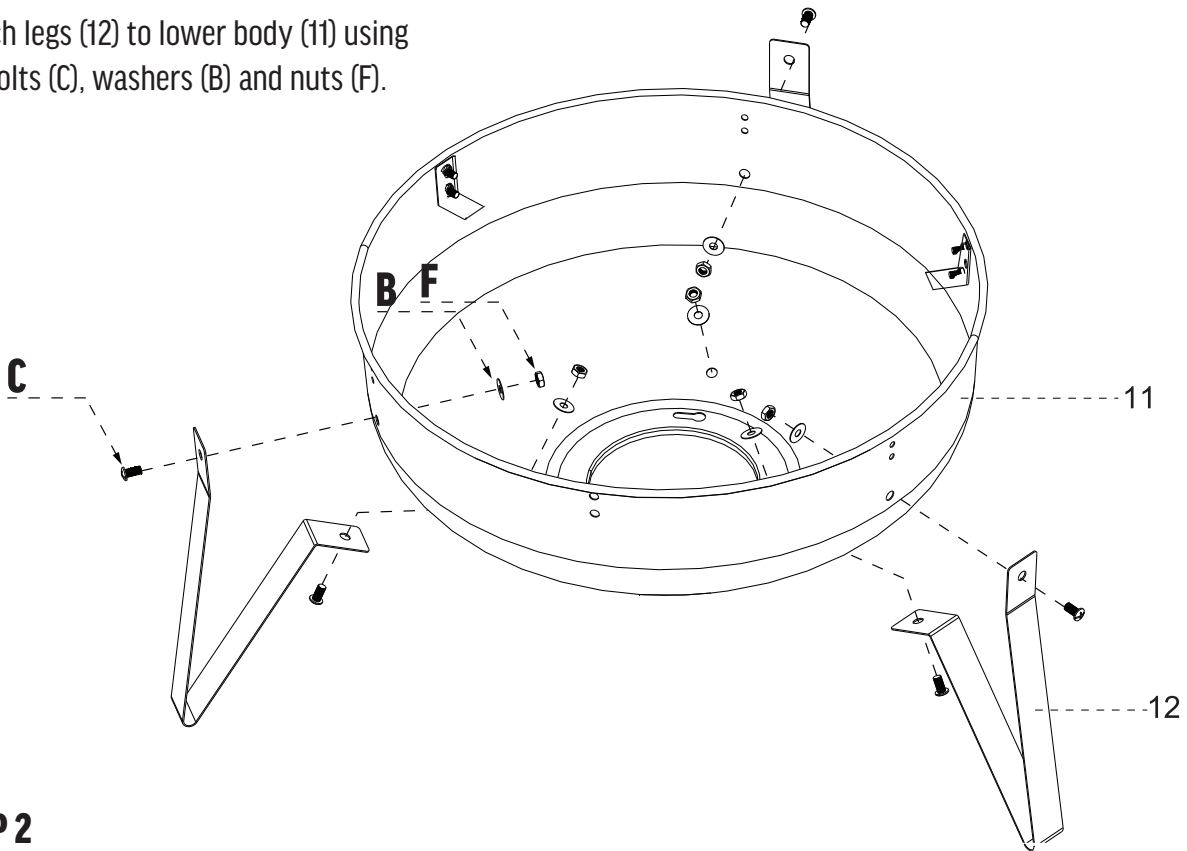

STEP 2

Attach 3 x latches (14), using 6 x bolts (A) and nuts (D). Insert bottom vent/ash collector (13) into lower body (11).

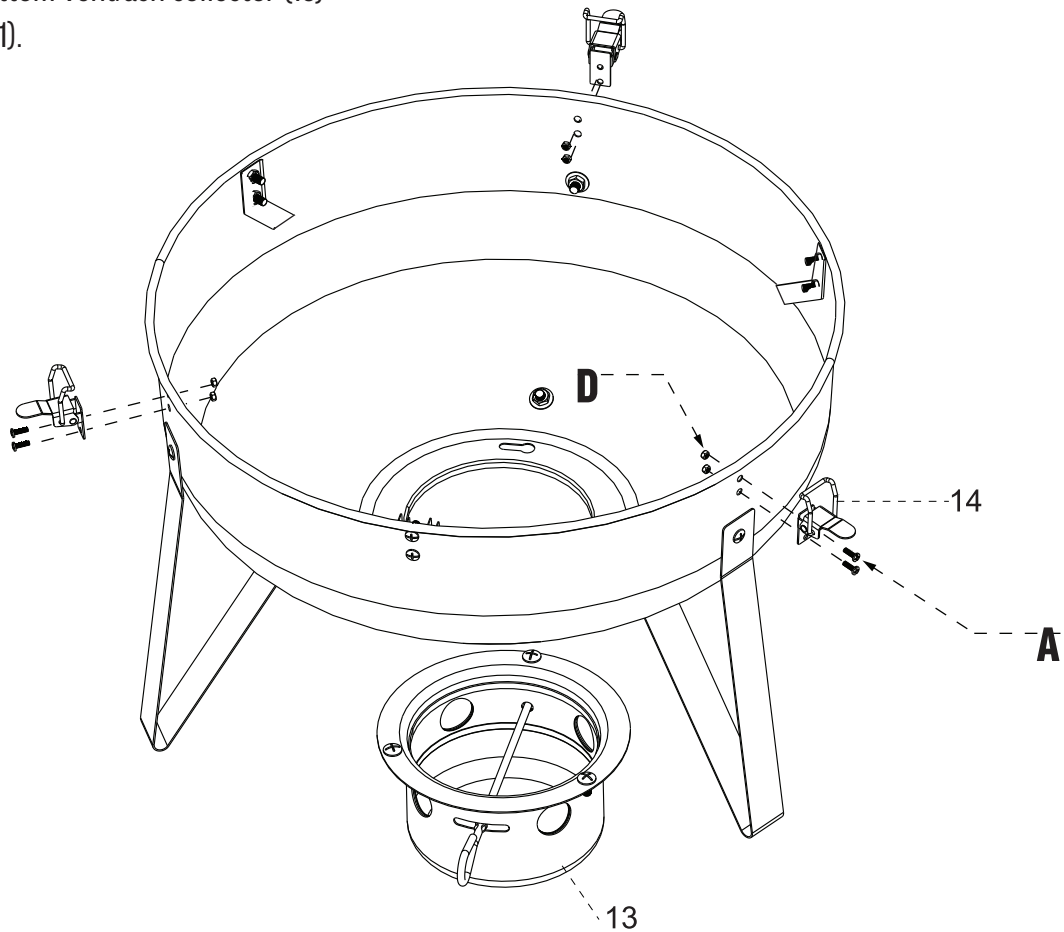

STEP 3

Attach 2 x handles (3) to upper body (7) using 4 x washers (B) and wing nuts (G). Attach 3 x grill support brackets (2) using 6 x bolts (H) and nuts (E).

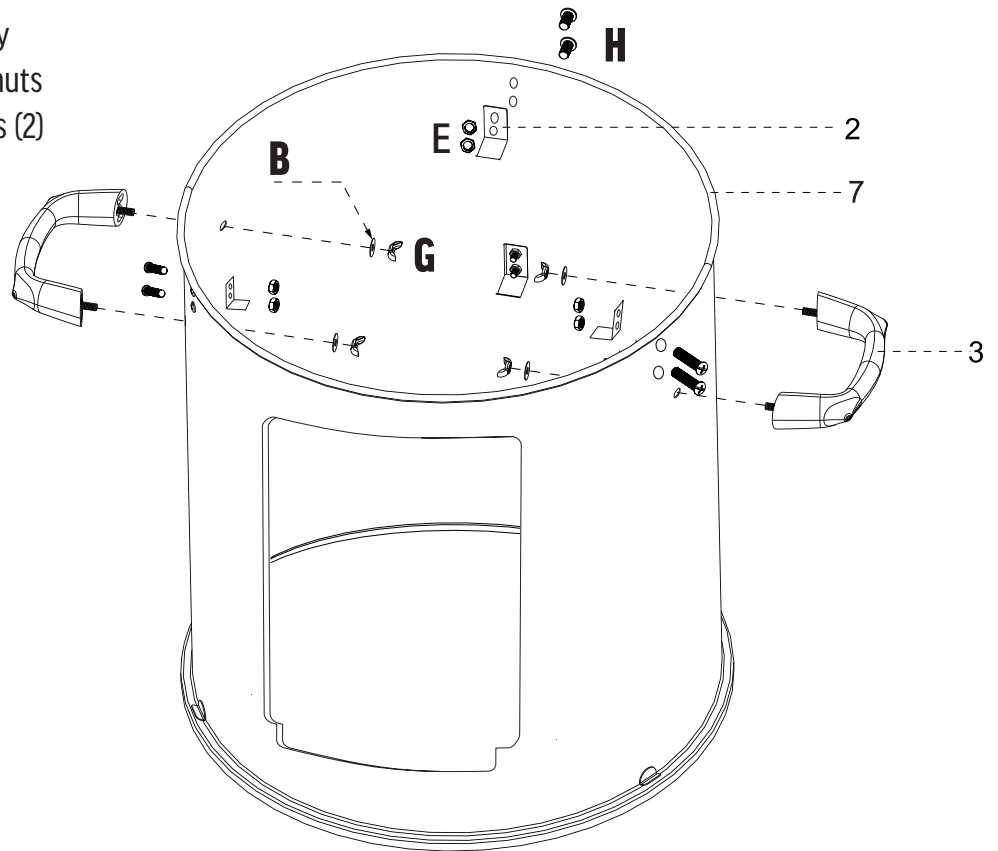

STEP 4

Attach handle (3) to the dome lid (1) using 2 x washers (B) and wing nuts (G). Attach ventilation plate (15) and Lid Vent (4) to the dome lid (1) using bolt (H) and nut (E). Insert temperature gauge (16) and attach using backing nut provided.

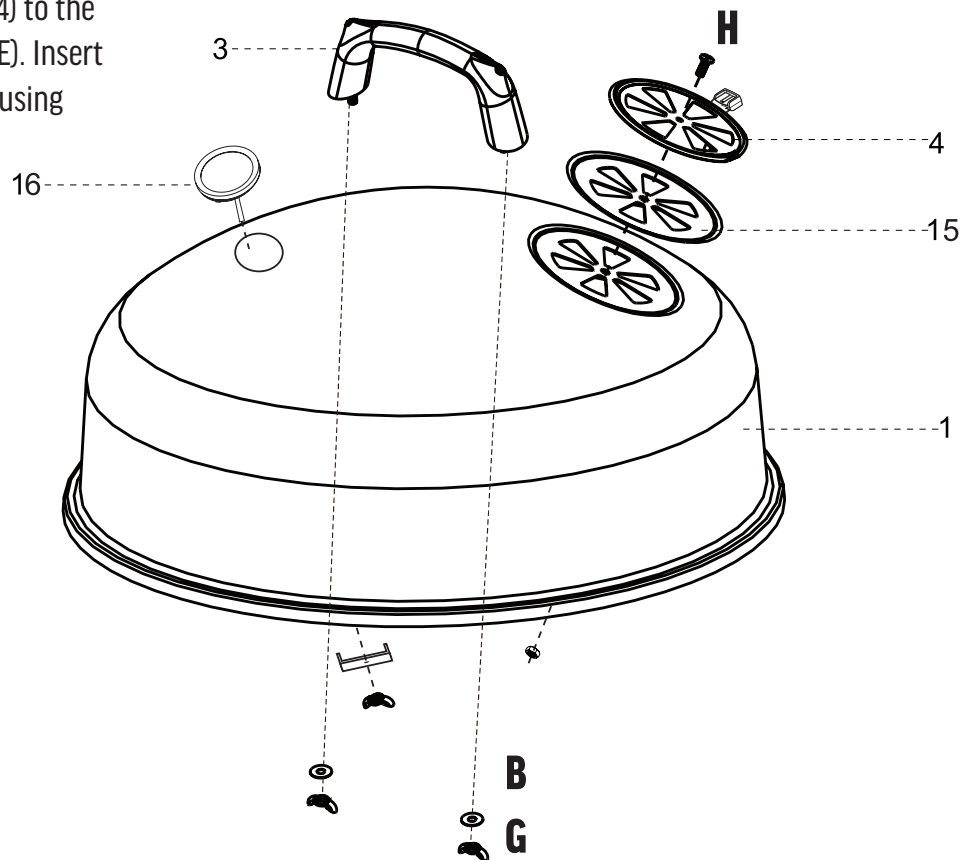

STEP 5

Assemble as per diagram.

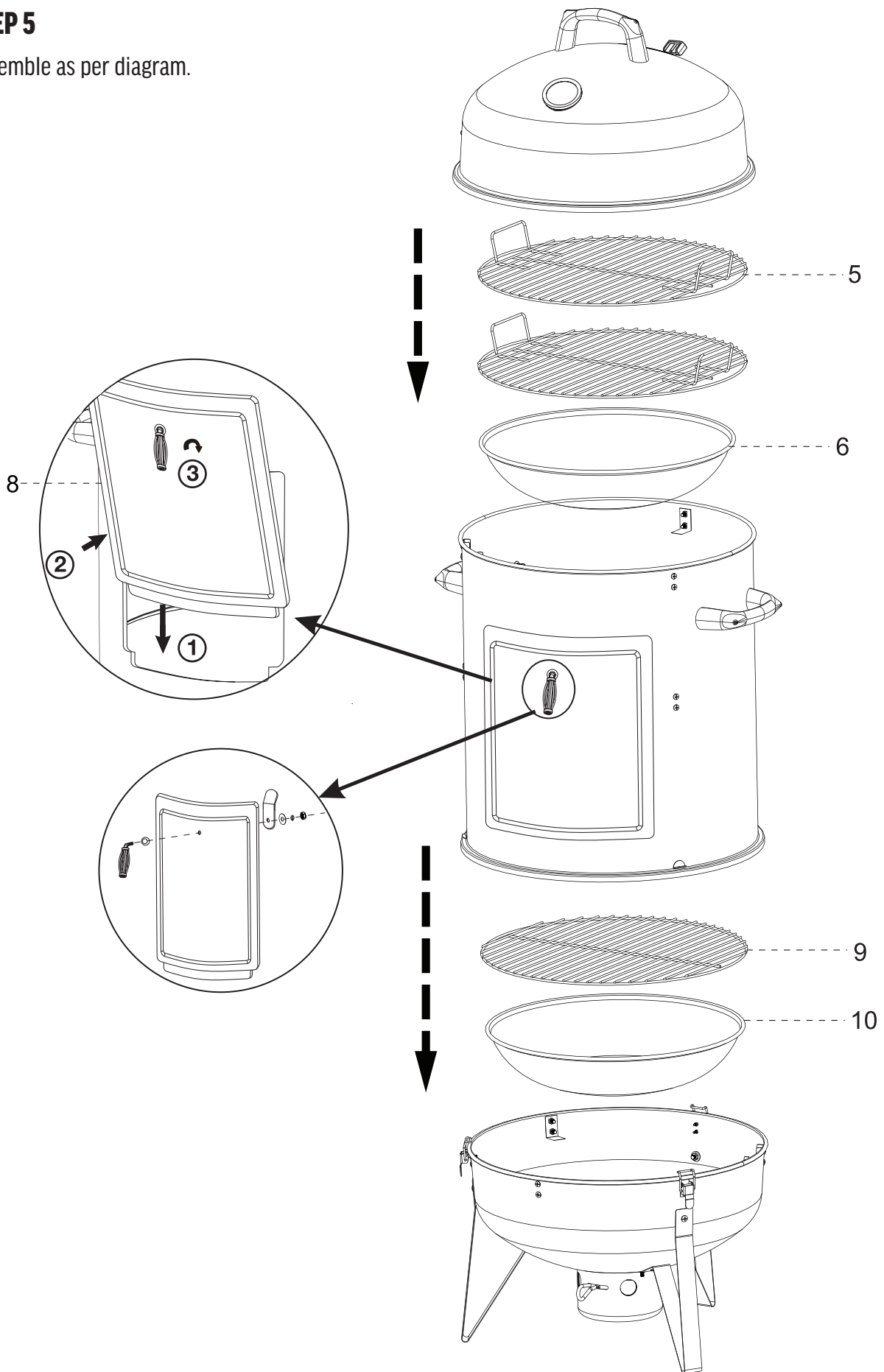

SAFETY, CARE AND MAINTENANCE



WARNING

Place the Smoker & Grill outdoors on a hard, level and non-combustible surface away from roof overhangs or any combustible material. Never use on wooden or other surfaces that could burn. Place the Smoker & Grill away from open windows or doors to prevent smoke from entering your house. In windy weather, place the Smoker & Grill in an outdoor area that is protected from the wind. Read all safety warnings and instructions carefully before operating your Smoker & Grill.

The water in water bowl will be extremely hot. When lifting upper body from lower body, use extreme caution and make sure the water bowl is securely in place on the three lower support brackets. Keep legs and feet out from under the upper body to avoid being scalded by hot liquids spilling from water bowl. Be extremely careful not to tilt or jar the Smoker & Grill so that hot water does not spill out of water bowl.

AFTER-USE SAFETY



WARNING

- Always allow Smoker & Grill and all components to cool completely before handling.
- Never leave coals and ashes in Smoker & Grill unattended.
- Before Grill can be left unattended, remaining coals and ashes must be removed from Smoker & Grill. Use caution to protect yourself and property. Place remaining coals and ashes in a non-combustible metal container and completely saturate with water. Allow coals and water to remain in metal container 24 hours prior to disposing.
- With a garden hose, completely wet surface beneath and around the Smoker & Grill to extinguish any ashes, coals or embers which may have fallen during the cooking or cleaning process.
- Extinguished coals and ashes should be placed a safe distance from all structures and combustible materials.
- Cover and store Smoker & Grill in a protected area, out of reach of children.

CARE AND MAINTENANCE

- Wash cooking racks, water and charcoal pans with hot soapy water, rinse well and dry. Lightly coat cooking racks with vegetable oil or vegetable cooking spray.
- Clean inside and outside of Smoker & Grill by wiping off with a damp cloth. After cleaning, apply a light coat of vegetable oil or vegetable cooking spray to the interior surface of the dome lid, smoker body, cooking racks and water bowl. This simple process will help reduce interior rusting. Do not apply oil to the charcoal pan.

Note: Smoke will accumulate and leave a residue in the dome lid of your unit that may drip onto food

during cooking. To minimize accumulation of residue, wipe off dome lid after each use.

- If rust appears on the exterior surface of your Smoker & Grill, clean and buff the affected area with steel wool or fine grit emery cloth. Touch-up with a good high-temperature resistant paint.
- Never apply paint to the interior surface. Rust spots on the interior surface can be buffed, cleaned, then lightly coated with vegetable oil or vegetable cooking spray to minimize rusting.
- Always keep your Smoker & Grill covered when not in use to protect against excessive rusting.

DO NOT OVER CLEAN, AS THIS CAN CAUSE DAMAGE TO THE SURFACE OF THE METAL AND CAN VOID THE WARRANTY

COOKING INSTRUCTIONS

SMOKING

1. Remove dome lid and upper body from lower body.
2. Always use high quality charcoal. We recommend using a Charmate Chimney Starter which speeds up the lighting process and avoids the dangers associated with charcoal lighter fluid. Directions for use can be found with the Chimney Starter.
3. If you do not use a Chimney Starter, carefully place 2.5 to 3.5 kilos of charcoal in the charcoal bowl.
4. A lot of wood is not required to obtain a good smoke flavour. A recommended amount is 3 to 4 wood chunks or sticks. Experiment by using more wood for stronger smoke flavour or less wood for milder smoke flavour.
5. Carefully light the charcoal and allow to burn until covered with a light ash prior to closing door. This may take up to 30 minutes.
6. Place empty water bowl inside Smoker & Grill body on the lower support brackets.
7. Carefully, fill water bowl with warm water or marinade to 2.5cm below the rim. A full pan holds 4.5 – 5.5 litres of water and will last for approximately 3 to 4 hours.
8. Place a cooking rack on the lower support brackets directly above the water bowl.
9. Place food on the cooking rack in a single layer with space between each piece. This will allow smoke and moist heat to circulate evenly around all pieces of food.
10. Place the upper body on lower body making sure the water bowl is still in place.
11. Place the other cooking rack on the upper support brackets. Make sure the rim is resting securely on the notched-out step of all three-support brackets. Place food on the cooking rack and cover with dome.
12. Allow food to cook. After 3 to 4 hours of cooking, check water level and refer to “Adding Water or Wood during Cooking” section of this manual.
13. Always use a meat thermometer to ensure food is fully cooked before removing from Smoker & Grill.
14. After cooking, allow Smoker & Grill to cool completely then follow instructions in the “Maintenance” section of this manual.

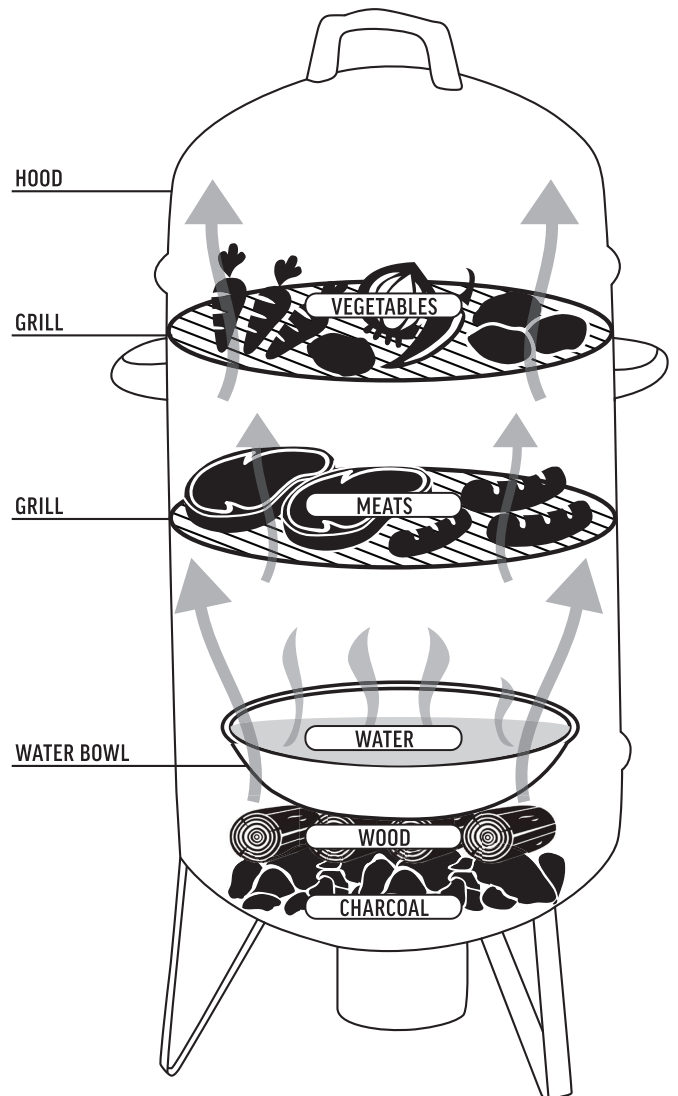

GRILLING & SEARING

1. Remove dome lid and upper body from lower body.
2. Always use high quality charcoal. We recommend using a Charmate Chimney Starter which speeds up the lighting process and avoids the dangers associated with charcoal lighter fluid. Directions for use can be found with the Chimney Starter.
3. If you do not use a Chimney Starter, carefully place 2.5 - 3.5 kilos of charcoal in the charcoal bowl. If you chose to use lighter fluid or fire starters carefully follow the manufacturer's warnings.
4. If using lighter fluid (only use lighting fluid approved for lighting charcoal), saturate charcoal with lighter fluid and wait 2 to 3 minutes for fluid to soak in. Store charcoal lighter fluid safely away from Smoker & Grill.
5. Carefully light the charcoal and allow to burn until covered with a light ash prior to closing door and continuing to Step 6. This may take up to 30 minutes, if you use a Charmate Chimney Starter this may take less time.



WARNING

Failure to do this could trap fumes from charcoal lighting fluid in Smoker & Grill and may result in a flash-fire or explosion when door is opened or dome lid is removed.

6. Place a cooking rack on the lower body.
7. Place food on the cooking rack in a single layer with space between each piece.
8. For best results, the dome lid should be placed on the lower body when grilling food.
9. Always use a meat thermometer to ensure food is fully cooked before removing from Smoker & Grill.
10. After cooking, allow Smoker & Grill to cool completely then follow instructions in the "Maintenance" section of this manual.



WARNING

When grilling, dripping from meat may cause flame flare-ups. Use extreme caution when removing the dome lid. Do not use water to extinguish a grease fire.

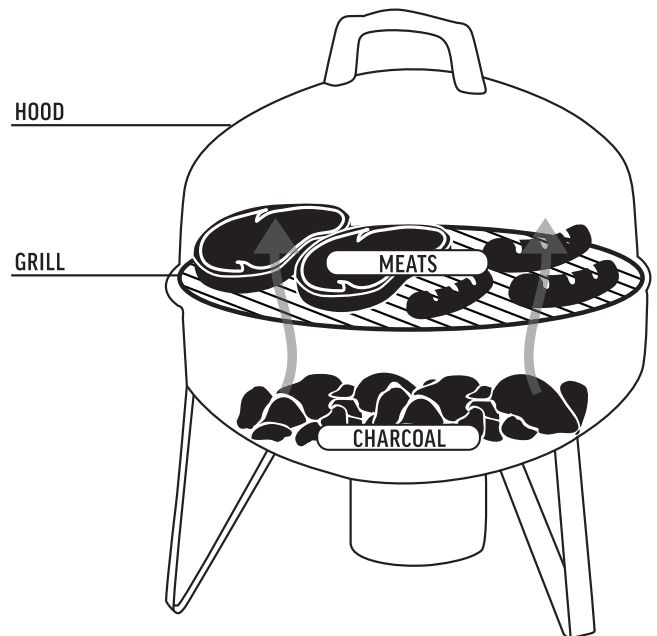

ROASTING

1. Remove dome lid and upper body from lower body.
2. Always use high quality charcoal. We recommend using a Charmate Chimney Starter which speeds up the lighting process and avoids the dangers associated with charcoal lighter fluid. Directions for use can be found with the Chimney Starter.
3. If you do not use a Chimney Starter, carefully place 2.5 - 3.5 kilos of charcoal in the charcoal bowl. If you chose to use lighter fluid or fire starters carefully follow the manufacturer's warnings.
4. If using lighter fluid, saturate charcoal with lighter fluid and wait 2 to 3 minutes for fluid to soak in. Store charcoal lighter fluid safely away from Smoker & Grill.
5. Carefully light the charcoal and allow to burn until covered with a light ash prior to closing door.
6. Place a cooking rack on the lower body.
7. Place food on the cooking rack in a single layer with space between each piece.
8. For best results, the dome lid should be placed on the lower body when grilling food.
9. Always use a meat thermometer to ensure food is fully cooked before removing from Smoker & Grill.
10. After cooking, allow Smoker & Grill to cool completely then follow instructions in the "Maintenance" section of this manual.

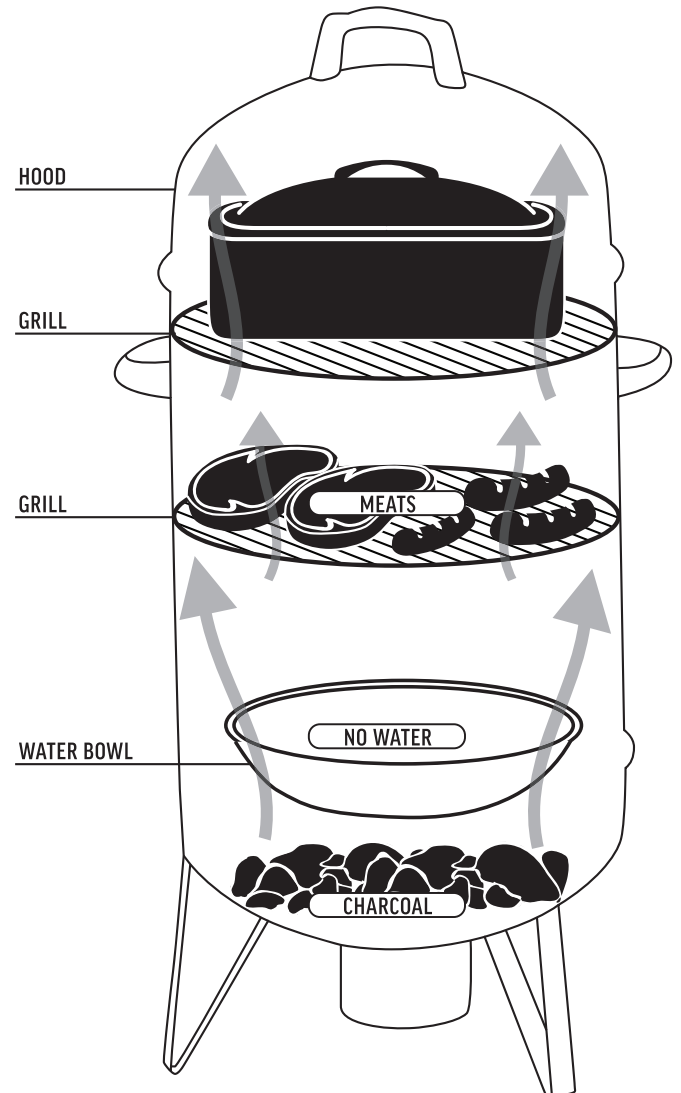

OPERATING INSTRUCTIONS

LIGHTING YOUR CHARMATE SMOKER

Place the Smoker & Grill outdoors on a hard, level and non-combustible surface away from roof overhangs or any combustible material. Never use on wooden or other surfaces that could burn. Place the Smoker & Grill away from open windows or doors to prevent smoke from entering your house. In windy weather, place the Smoker & Grill in an outdoor area that is protected from the wind. Read all safety warnings and instructions carefully before operating your Smoker & Grill.

FLAVOURING WOOD

To obtain your favourite smoke flavour, experiment by using chunks, sticks or chips of flavour-producing wood such as manuka, apple or cherry. Most fruit or nut tree wood can be used for smoke flavouring. Do not use resinous woods such as pine as it will produce an unpleasant taste. Wood chunks or sticks 7.5 - 10cm long and 1.25 - 2.5cm thick work best. Unless the wood is still green, soak the wood in water for 20 minutes or wrap each piece in foil and tear several small holes in the foil to produce more smoke and prevent the wood from burning too quickly.

ADDING WATER OR WOOD DURING COOKING

Additional flavouring wood should not have to be added during the cooking process, however it may be necessary when cooking very large pieces of meat. Follow the instructions and cautions below to avoid injury while adding water and/or wood.

1. Remove dome lid by tilting it away from you to allow heat and steam to escape away from your face. Use caution since flames can flare-up when fresh air suddenly comes in contact with fire.
2. Wearing oven mitts carefully remove upper body from lower body.
3. Set the upper body on a hard, level non-combustible surface.
4. Stand back a safe distance and use long cooking tongs to add wood, being careful not to splash water.
5. If water level is low, add water to bowl. If food is on top cooking rack only, water may be added to the bowl by moving food aside on cooking rack and pouring water down through the cooking rack. Fill water bowl to 2.5cm below the rim. Pour slowly to avoid splashing or overfilling.
6. Using oven mitts replace upper body on lower body.
7. The water in water bowl will be extremely hot. When lifting Smoker & Grill body from ground, use extreme caution and make sure the water bowl is securely in place on the three lower support brackets. Keep legs and feet out from under Smoker & Grill body to avoid being scalded by hot liquids spilling from water bowl.
8. Replace food on cooking racks then place the dome lid on upper body.



WARNING

The water in water bowl will be extremely hot. When lifting upper body from lower body, use extreme caution and make sure the water bowl is securely in place on the three lower support brackets. Keep legs and feet out from under the upper body to avoid being scalded by hot liquids spilling from water bowl. Be extremely careful not to tilt or jar the Smoker & Grill so that hot water does not spill out of water bowl.

RECIPES

SMOKED CHICKEN

1 chicken

50ml olive oil

Juice of one lemon

Salt & Pepper

Mix the olive oil and lemon juice together in a cup or ramekin and then use a meat injector to inject into the breast and the thighs. Use the last few drops of the mix to rub over the skin and then sprinkle with salt and pepper. Load the chicken onto the cooking rack and place it in the smoker at 110°C or 225°F for 60 minutes per .5 kilo.

It's important to make sure the chicken is properly cooked so ensure the juices run clear when a skewer is placed in the meat or use a thermometer. Breast meat should be at 165°F and thigh meat at 175°F.

SMOKED HERBED CHICKEN

1 (approx. 2 kilos) whole chicken

45 g butter

4 g chopped fresh parsley

6 g chopped fresh oregano

3 g chopped fresh basil

3 g fresh chives, finely chopped

Preheat outdoor Smoker & Grill for low heat. Using hickory is a great option if you want to add additional flavour to the chicken.

Rinse chicken inside and out and pat dry. Loosen skin around the breast area.

Place three tablespoons of butter in various places under the skin. Mix herbs together and place half under the skin and the other half inside the chicken.

Cook chicken in Smoker & Grill for 4 hours or until juices run clear when poked with a fork.

SMOKED MUSSELS

Steam required quantity of mussels open. Marinate in sweet chilli sauce for 4 - 24 hours with a little brown sugar added. Smoke for approximately 20 minutes.

MANUKA SMOKED TROUT

120 g x 4 portions Trout

Brown sugar

Salt & Pepper

2 handfuls Manuka chips

Coriander

Fillet trout taking care to remove all bones. Tie 2 fillets together at a time with string, having placed a sprig of coriander inside each. Sprinkle trout with the brown sugar, salt and pepper. Place Manuka wood chips into Smoker & Grill and place seasoned fish onto the grill above the chips.

Starting with a high heat to get a strong scent of Manuka, then turning down to allow a slow consistent cooking with the Manuka smoke. This results in a beautiful caramel colour and tender pink centres. When cooked, remove string and serve as required.

SMOKED MUSHROOMS

4 cups mushrooms

2 tablespoons lemon pepper

2 tablespoons garlic powder

Cut mushroom stems off and wash. Sprinkle lemon pepper and garlic powder lightly over mushrooms. Smoke at 225°F for 45 minutes. Cool; serve immediately.

SMOKED CORN ON THE COB

6 to 12 ears of corn with husks on

1/2 cup olive oil

1 bunch finely chopped green onions (including tops)

Gently pull back the husks on the each ear. Remove the silk but not the husks. Place the ears in a large pot and cover with water. Let sit for several hours.

Remove from water and brush each ear of corn with olive oil, then sprinkle about 2 teaspoons green onion over. Cover corn with husks. Repeat with each ear of corn.

Prepare smoker. The ears of corn will need to smoke at 225°F for about 1 1/2 hours.

When done smoking, remove husks and eat.

COOKING TIPS

- Variations in flavour can be achieved by adding wine, soft drinks, herbs, spices, bits of citrus peel, fruit juice, onion or marinades to the water bowl.
- Brush poultry and naturally lean meats with cooking oil, butter or margarine before cooking.
- Meat should be completely thawed before cooking.
- When cooking more than one piece of meat, the cooking time is determined by the largest single piece being cooked.
- The meat bastes itself while cooking in the Smoker & Grill. No basting or turning is necessary after the meat is placed on the rack. For added variety, barbecue sauce or marinade may be applied on meat before placing on rack.
- There is very little difference in temperature and cooking time between top and bottom rack levels. When cooking different types or cuts of meat at the same time, place the meat that requires the least cooking time on the top cooking rack so that it may be easily removed first. If only one cooking rack is required, use the upper rack level for the best result.
- During the smoking process, avoid the temptation to lift dome lid to check food. Lifting the dome lid allows heat to escape, making additional cooking time necessary.
- Always use a meat thermometer to determine if food is done. Many variables (outside cooking temperature, amount of charcoal, the number of times the dome lid is removed, proximity of food to heat source, etc) will affect actual cooking times. When using a meat thermometer, place probe mid-way into the thickest part of the meat, making sure that it does not touch any fat or bone. Allow five minutes for the thermometer to properly regulate temperature.
- Food safety is a very important part of enjoying the outdoor cooking experience. To keep food safe from harmful bacteria, follow these four basic steps:
Clean: Wash hands, utensils, and surfaces with hot soapy water before and after handling raw meat.
Separate: Separate raw meats from ready-to-eat foods to avoid cross contamination. Use a clean platter and utensils when removing cooked foods.

Cook: Cook meat and poultry thoroughly to kill bacteria. Use a thermometer to ensure proper internal food temperatures.

Chill: Refrigerate prepared foods and leftovers promptly.

For further Food Safe information, go to New Zealand Food Standards website: www.mpi.govt.nz/food-safety/food-safety-for-consumers.

Aber Living warrants the purchaser of this product against defects in workmanship and material, for a period of up to 12 months from the date of purchase. The warranty is non-transferable and becomes void if used for commercial or rental purposes.

Warranty and purchase receipt of this product are to be retained as proof of purchase and must be presented if making a claim under the terms of the Aber Living Warranty. Repairs under warranty are free of charge, provided the product is delivered to our Service Department or Authorised Service Agent and freight charges both ways are paid by the owner. No liability will be accepted for any loss of damage in transit.

Aber Living reserves the rights to replace or repair the product within the warranty period. Warranty does not apply to any defect, deterioration (including corrosion if located within 1km of the sea), loss, injury or damage occasioned by or as a result of the misuse or abuse, negligent handling or if the product has not been installed and used in accordance with the instructions. The warranty is void if there is evidence of the product being tampered with by unauthorised persons.

If the product includes one or a number of accessories, only the defective accessory or part will be replaced.

In the event of Aber Living choosing to replace the product, the warranty will expire at the original date, i.e. 12 months from the original purchase date.

Where this product contains information from an overseas country, nothing in that information is intended to limit any condition, guarantee, right or remedy which may be available under the Consumer Guarantees Act 1993, except to the extent permitted by that Act.

Approved for Outdoor Use Only.

For service, spare parts or product information in New Zealand, please call Aber Living on the Customer Service Line - 0800 161 161. www.aberliving.co.nz

YOUR PURCHASE RECORD (please complete)

Date of Purchase _____

Model Number _____

Serial Number (if applicable) _____

Purchased from _____